

**\*\*PRODUCT VIEWED FEATURES NO GLASS COVER LAYER\*\***  
**CONTACT GUNZE USA FOR YOUR GLASS COVER LAYER OPTIONS.**

| REVISIONS |                 |          |
|-----------|-----------------|----------|
| REV.      | DESCRIPTION     | DATE     |
| 0         | INITIAL RELEASE | 08/24/15 |
| 1         |                 | 03/15/16 |
|           |                 |          |
|           |                 |          |
|           |                 |          |
|           |                 |          |
|           |                 |          |

- GENERAL NOTES:
- MAX. VOLTAGE:  
3-5 V
  - OPERATION TEMPERATURE:  
-10° TO 60°C
  - HUMIDITY:  
< 40°C 20% to 95% RH NO  
CONDENSATION.
  - STORAGE TEMPERATURE:  
-20°C TO 70°C
  - FFC BEND R > 2.0MM  
NO SHARP CREASE
  - TP CONTROLLER INFO:  
USB - PART #1005-0160  
CABLE - PART # TBD
  - OPTICAL PER.  
84% TRANSPARENCY  
PER JIS K7361-1

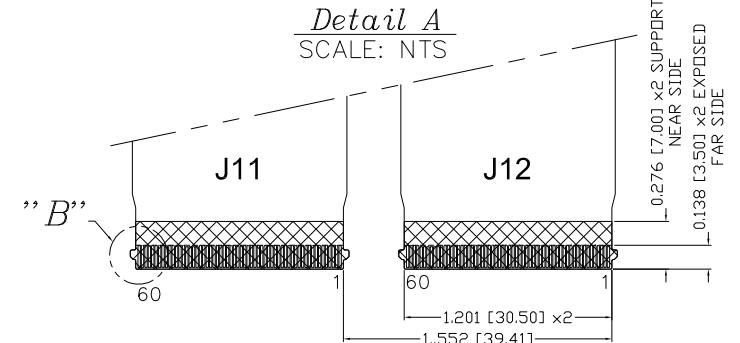
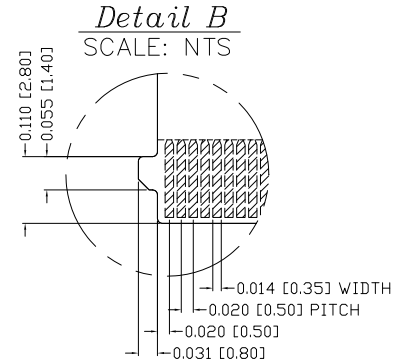
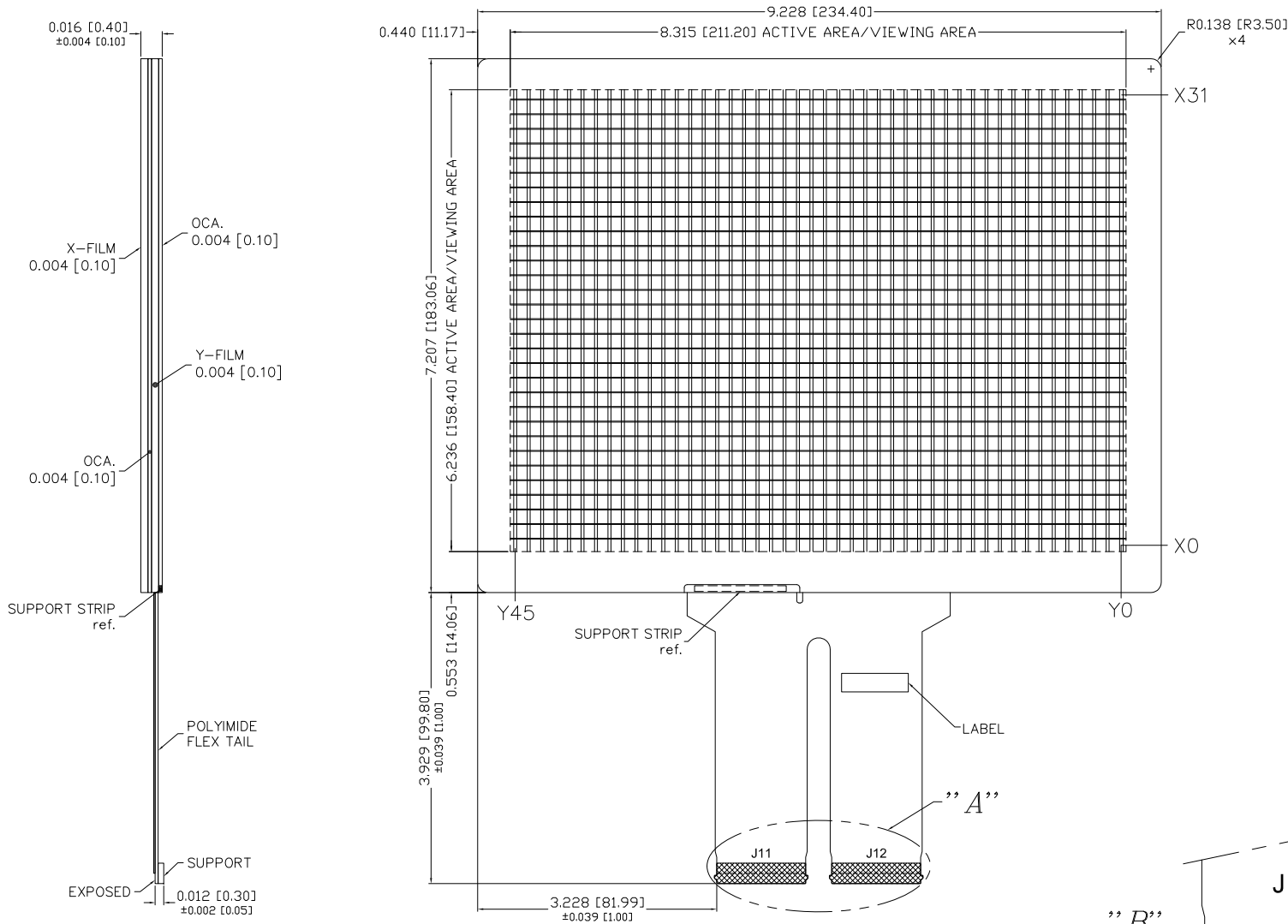

**Key Matrix**

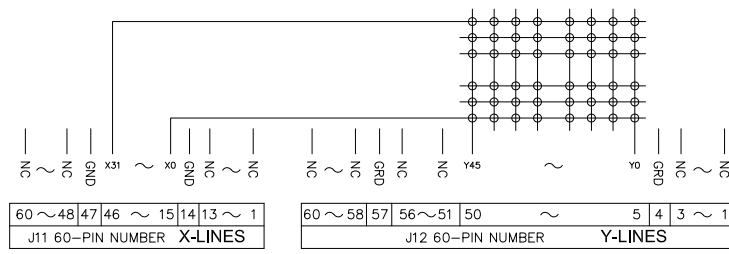

|   |   |  |                       |  |
|---|---|--|-----------------------|--|
| <b>CAD DRAWING</b><br><b>NOTICE</b><br>THIS DRAWING EMBODIES A PROPRIETARY DESIGN ORIGINATED BY GUNZE ELECTRONICS USA CORPORATION AND SHALL NOT BE DISCLOSED, USED, OR DUPLICATED FOR PROCUREMENT OR MANUFACTURING PURPOSES, UNLESS SPECIFICALLY AUTHORIZED BY GUNZE ELECTRONICS USA CORPORATION. ALL PATENT RIGHTS RELATING HERETO ARE EXPRESSLY RESERVED FOR GUNZE ELECTRONICS USA CORPORATION.<br>This notice shall be marked on any reproduction hereof in whole or part. | DEC. TOLERANCES:<br><b>.XXX = ±0.012</b><br><b>[.XX] = ±[0.30]</b><br>ANGULAR TOL. = ±1°<br>FRAC. TOL. XX = ±1/16 | DESIGNER:<br><b>VTRINH</b> 08/24/15<br>CHRD.         |                       |  |
|   | DIM CODE: (INCHES) [MILLIMETERS]  | DESIGN ENG:<br><b>LHRUIZ</b> 08/24/15<br>VIEW POINT: |                       | TITLE:<br><b>10.4D, 32x46; P-CAP.ATMEL</b> |
|   | CUSTOMER R:   |  |                       | PART NO.<br><b>170-4001</b>                |
|   | MATERIAL SPEC.<br><b>P-Cap Internal</b>   | RELE.<br><b>03/15/16</b>                             |                       | SCALE:<br><b>2 : 1</b>                     |
| CUSTOMER ID:<br><b>GUNZE USA</b>  |   |  | REVISION:<br><b>0</b> |  |